

Shinhwa Pharma Tech

Summary description

Automatic capsule filling machine

Model: SPT- FS50



SHINHWA PHARMA TECH CO., LTD.

142, Venture Complex,
58, Gondan1-daero 363beon-gil,
Siheung-ci, Kyunggi-do, Korea



Auto. Capsule filling machine Model: SPT-FS50 Technical Spezifikation

1. Technical date

Description	SPT-FS50
Electrical connection	220V / 380V 50/60Hz, 3ph
Power input	6 kW
Max. output (Puder)	50,000 cap/h
Max. output (Pellet)	36,000 cap/h
Dimension of the machine	Approx. 1250 x 1500 x 1850 mm
Size of capsules	#00,#0, #1, #2, #3, #4 (Option: #000, #5)
Segments for capsules/ bore	12 seg / 6 bores
Max. Rotation of segment	130 rpm
Main motor power	0.75 kW
Rotation speed control	Inverter
Drive engineering	Roller gear cam indexing
Method of weight control	Disk thickness
Leistung Produkttrichtermotor	0.37 kW
Volume of product hopper	20 L
Volumen of capsule hopper	25 L
Compressed air	6 kg/cm ²
Vacuum pump	VTM100 (V-TEC)
Area for the machine	1250 x 1500 mm
Height of the machine (without hopper)	1650 mm
Height of the machine (with hopper)	1850 mm
Weight netto	1,470 kg

2. Working condition

1) Storage of capsules

- ① Temperature: max. 20 – 25 C°
- ② Air humidity : max. 50 %

2) Indoor- / working condition

- ① Temperature: max. 20 – 25 C°
- ② Air humidity : max. 40 – 50%

3. Machine drive and vacuum system

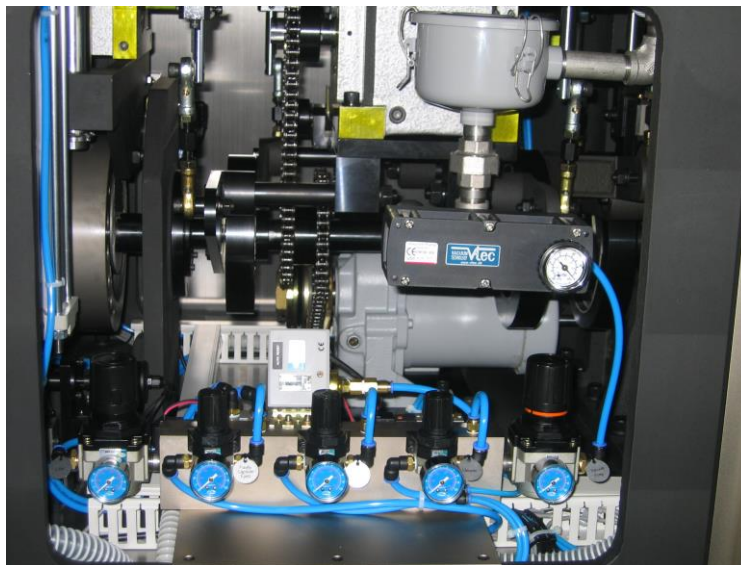

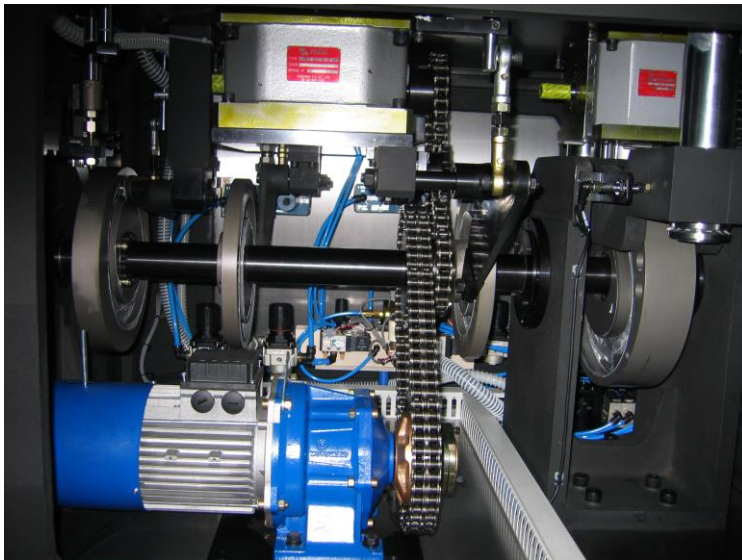

1. Vacuum pump with vacuum filter
2. Main drive

4. Dosing unit with hopper for powder

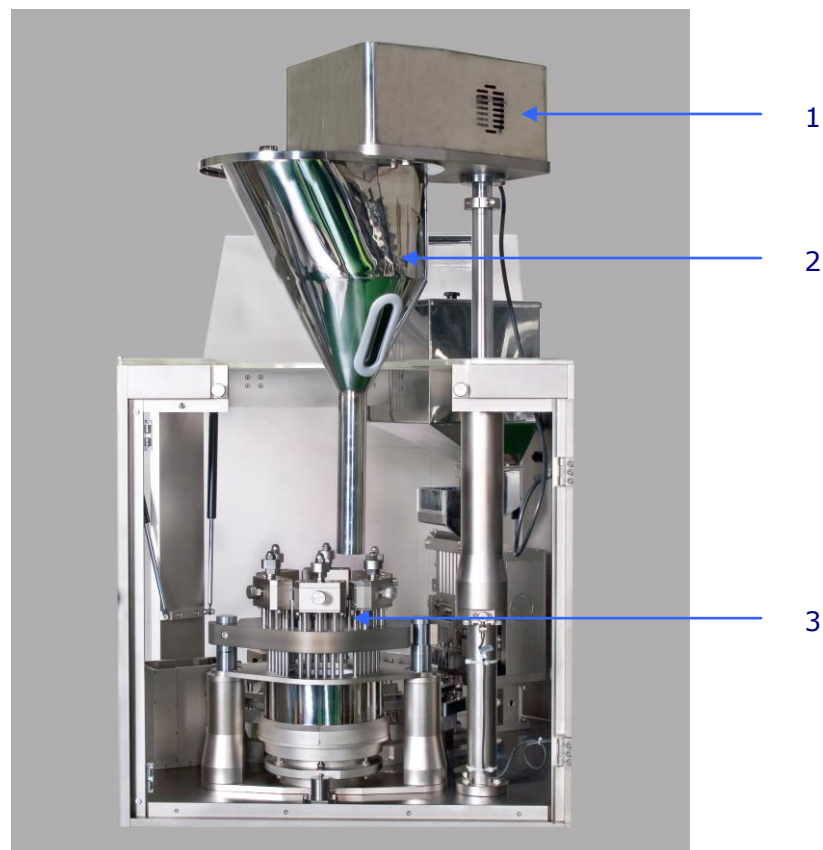

1. Machine drive for powder mixing
2. Hopper for powder
3. Dosiereinheit

5. Production room

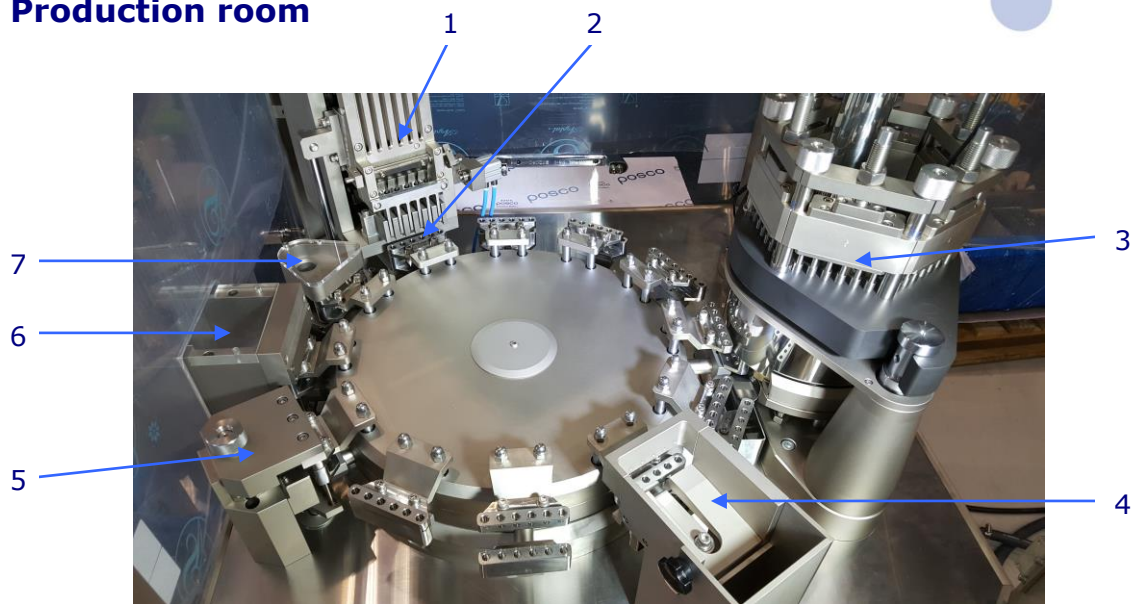

Production room

1. Capsules feeding
2. Capsules orientation and selection
3. Dosing unit
4. Reject of capsules
5. Station for closing of capsules
6. Tunnel for the filed capsules
7. Segment for cleaning tunnel

6. Layout Model: SPT-FS50

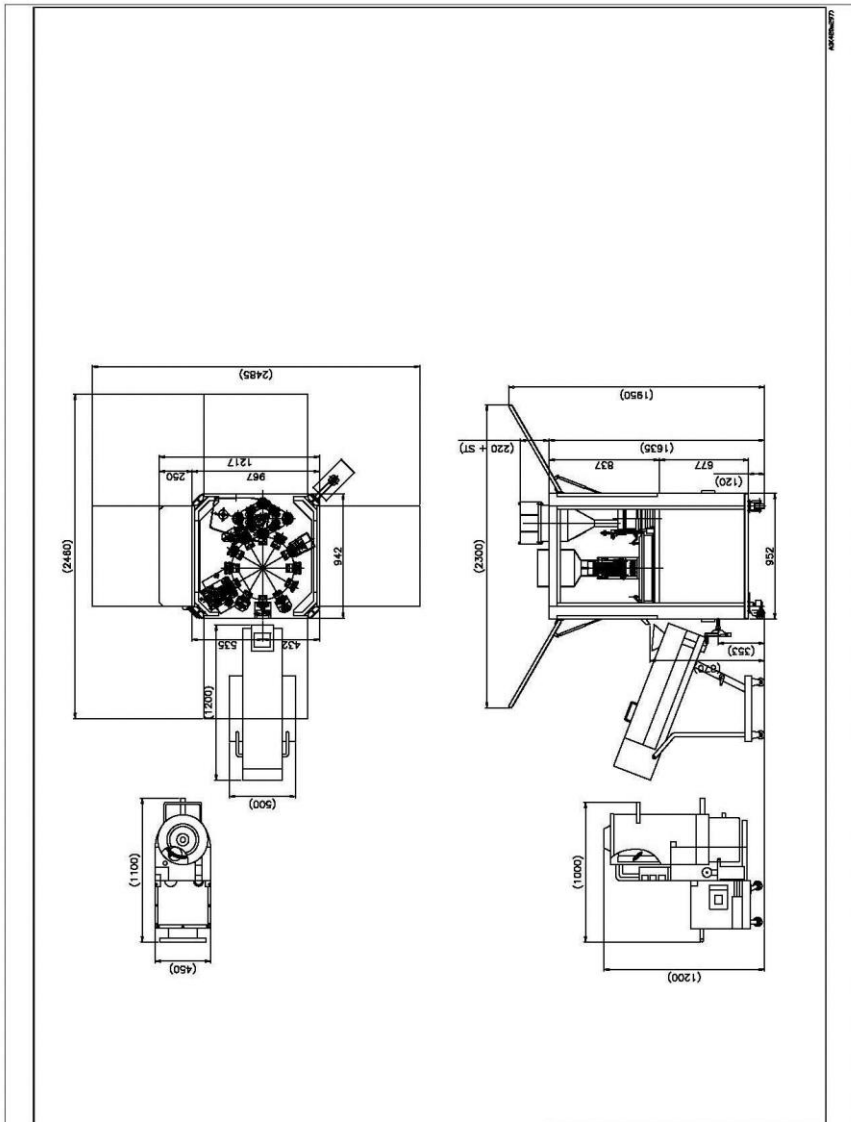

7. Options

Automatic powder loading system

Automatic loading system for capsules

Polishing machine for capsules

Vacuum cleaner

Format parts for capsule size: #00; #0; #1; #2; #3; #4
optional #000; #5