

**COA010.2.2**

**Coating pan STÖBER**

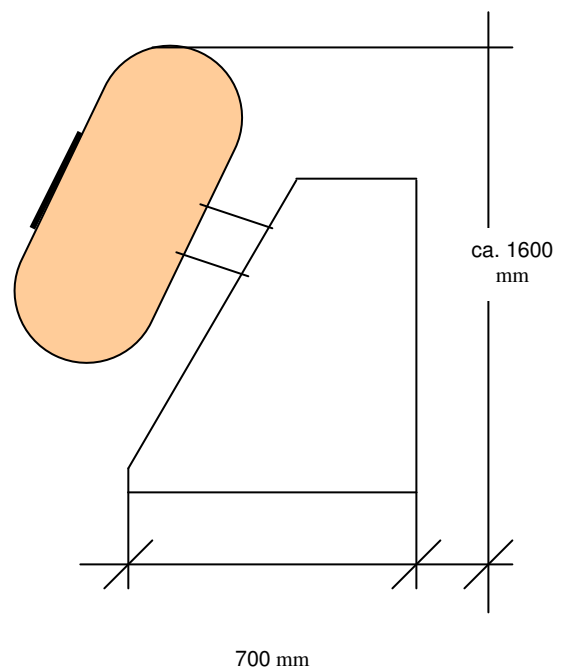
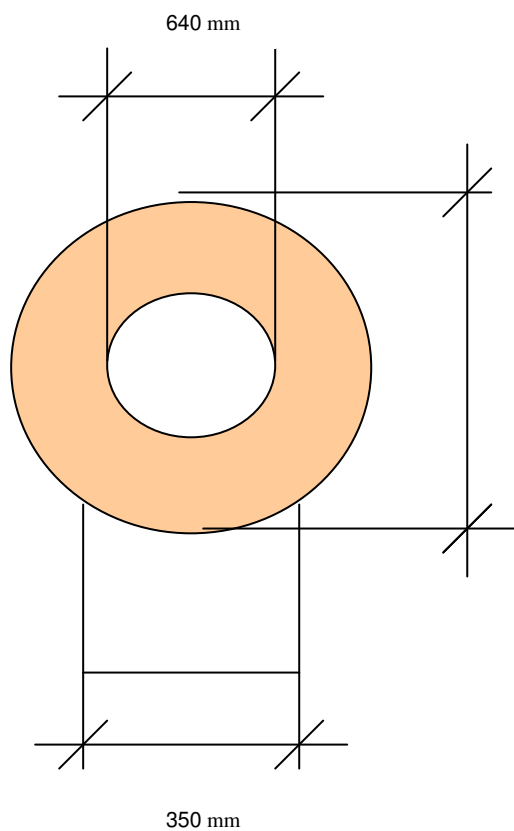

**Technical data:**

• <b>Producer:</b>	<b>STÖBER</b>
• <b>Size:</b>	<b>R44/6</b>
• <b>U/ min.:</b>	<b>55- 275</b>
• <b>Voltage:</b>	<b>220/380 V/AC</b>
• <b>Electricity:</b>	<b>4/2,4 A</b>
• <b>Leistung:</b>	<b>1,2 kW</b>
• <b>Loading volume:</b>	<b>35-40 kg</b>
• <b>Sugar coated product:</b>	<b>ca. 65 kg</b>
• <b>Drum diameter:</b>	<b>900 mm</b>
• <b>Drum depth:</b>	<b>450 mm</b>
• <b>Ladeöffnung, diameter</b>	<b>640 mm</b>
• <b>Speed Frequency</b>	<b>variable</b>
• <b>Drum pitch</b>	<b>variable</b>

**1 Coating pan STÖBER with variable drum pitch**

**2 Coating pan STÖBER without variable drum pitch**